

Affordable Automation for Welding, Cutting and Semi-Automatic Processes

DC General Welding Kit

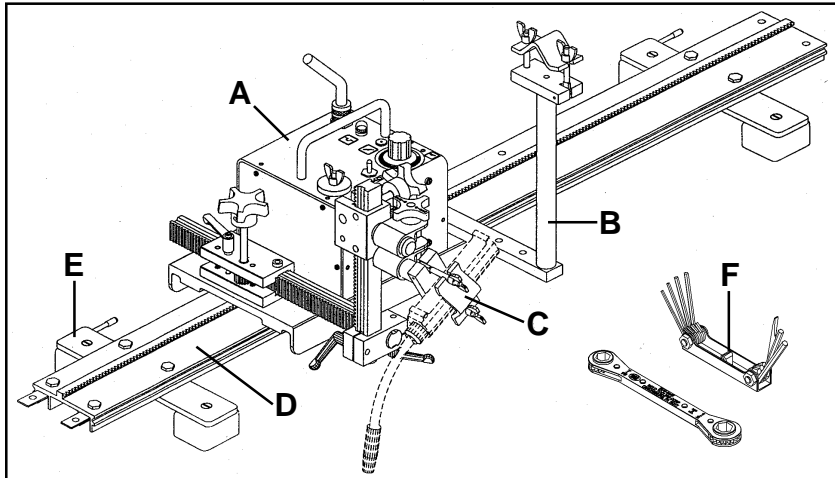
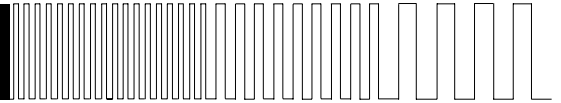

Features:

- A. BUG-O DC IV
- B. Cable Mounting Assembly
- C. Machined Rack Welding Group
- D. Heavy Duty Rigid Rail
- E. Magnet Bar Swivel w/Release
- F. Tool Kit

Technical Data:

Power Requirements:	BUG-1950	120VAC/50-60/1
	BUG-1951	240VAC/50-60/1
	BUG-1952	42VAC/50-60/1

Travel Speed: *1.5-30 ipm (38-760 mm/min)

Load Capacity: 50 lbs (22.7 kg) Vertical
120 lbs (54.4 kg) Horizontal

Net Weight of Kit: 60 lbs. (27.3 kg)

Shipping Weight of Kit: 79 lbs. (36 kg)

BUG-1950

**DC IV General Welding Kit
120 VAC (120/50-60/1)**

**Includes:
1 BUG-0343**

BUG-O DC IV
*1.5-30 ipm (38-760 mm/min)

**Includes:
1 BUG-9444 Tool Kit**

**1 BUG-2975
1 MDS-1040
1 ARR-1080
1 ARR-1085
5 ARM-2325**

Cable Mounting Assembly
Machined Rack Welding Group
Heavy-Duty Rigid Rail 8' (2.37 m)
Heavy-Duty Rigid Rail 4' (1.18 m)
Swivel Magnet Plate w/Release

BUG-1951

DC IV General Welding Kit 240 VAC
Same as above except with BUG-0443

BUG-1952

DC IV General Welding Kit 42 VAC
Same as above except with BUG-0543

***NOTE:** With the bypass pinion installed, the DC IV will have an increased speed range (8-160 ipm: 200-4000 mm/min), however, vertical load carrying capability will be reduced to 3 lbs. (1.4 kg).

Factory Installed Options:

BUG-1635_ Pendant Control with Weld Starter
(Specify Length Desired). Available in 10.0" (3.0 m) and 25.0'
(7.6 m) lengths. **Includes:** Speed Control Knob and Forward-
Off-Reverse Travel Switch and Weld Contactor Switch.

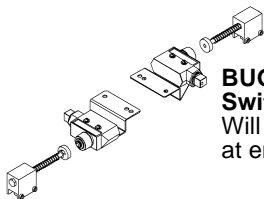

**BUG-9770 Limit
Switch Kit**
Will stop the drive
at end of travel.

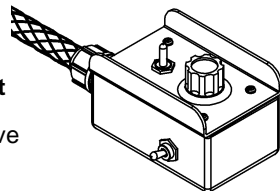

Available Separately:

BUG-9865
Stepping module bolts to DC Drive.
When limit switch is tripped, module
provides adjustable-timed power (0-3
seconds) to the DC Drive.

**BUG-2205 Carriage
Trailer with Hitch**

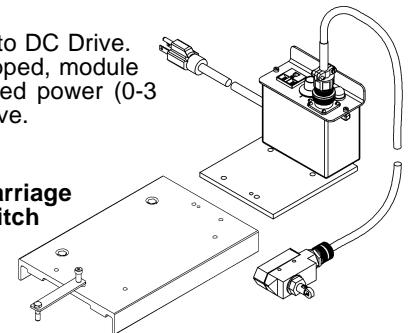

BUG-O SYSTEMS
A DIVISION OF WELD TOOLING CORPORATION



280 TECHNOLOGY DRIVE CANONSBURG, PENNSYLVANIA 15317-9564 USA
PHONE: 1-412-331-1776 <http://www.bug-o.com> FAX: 1-412-331-0383

**Affordable Automation
for Welding, Cutting and
Semi-Automatic Processes**

DC Heavy-Duty Welding Kit

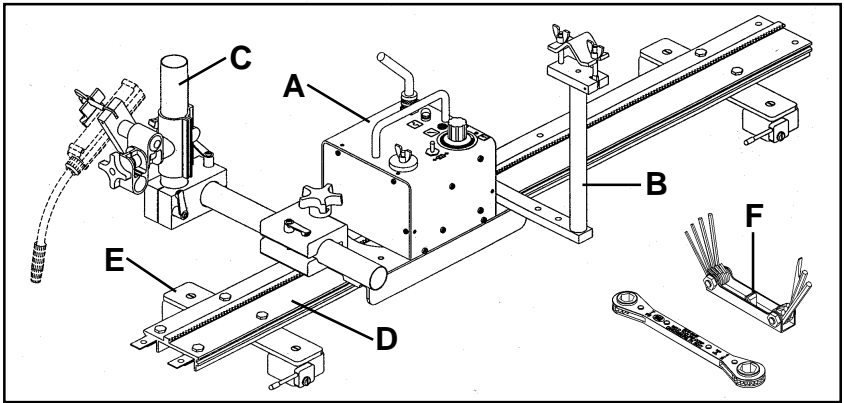

Features:

- A. BUG-O DC IV
- B. Cable Mounting Assembly
- C. H.D. Welding Group
- D. Heavy Duty Rigid Rail
- E. Magnet Bar Swivel w/Release
- F. Tool Kit

Technical Data:

Power Requirements:	BUG-1950-HD 120VAC/50-60/1 BUG-1951-HD 240VAC/50-60/1 BUG-1952-HD 42VAC/50-60/1	BUG-1950-HD	DC IV Heavy Duty Welding Kit (120/50-60/1)
Travel Speed:	*1.5-30 ipm (38-760 mm/min)	Includes:	BUG-O DC IV *1.5-30 ipm (38-760 mm/min) Includes: 1 BUG-9444 Tool Kit
Load Capacity:	50 lbs (22.7 kg) Vertical 120 lbs (54.4 kg) Horizontal	1 BUG-2975 1 BUG-5275 1 ARR-1080 1 ARR-1085 5 ARM-2325	Cable Mounting Assembly H.D. Welding Group Heavy-Duty Rigid Rail 8' (2.37 m) Heavy-Duty Rigid Rail 4' (1.18 m) Swivel Magnet Plate w/Release
Net Weight of Kit:	60 lbs (27.3 kg)	BUG-1951-HD	DC IV General Welding Kit-HD 240 VAC Same as above except with BUG-0443
Shipping Weight of Kit:	79 lbs (36 kg)	BUG-1952-HD	DC IV General Welding Kit 42 VAC Same as above except with BUG-0543

***NOTE:** With the bypass pinion installed, the DC IV will have an increased speed range (8-160 ipm: 200-4000 mm/min), however, vertical load carrying capability will be reduced to 3 lbs. (1.4 kg).

Factory Installed Options:

BUG-1635- Pendant Control with Weld Starter (Specify Length Desired). Available in 10.0" (3.0 m) and 25.0' (7.6 m) lengths. **Includes:** Speed Control Knob and Forward-Off-Reverse Travel Switch and Weld Contactor Switch.



BUG-9770 Limit Switch Kit
Will stop the drive at end of travel.

Available Separately:

BUG-9865
Stepping module bolts to DC Drive. When limit switch is tripped, module provides adjustable-timed power (0-3 seconds) to the DC Drive.

BUG-2205 Carriage Trailer with Hitch

